

**OPIC.43 – Impedance Converter with Adjustable Voltage Multiplier**  
**Updated stripboard version for LDC capsule – (simplified construction)**

**Designed to fit into a BM800 body**

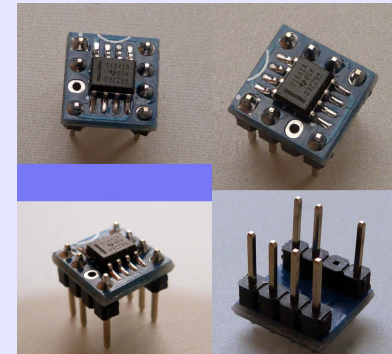

• Op Amp Impedance Converter (OPIC.43) STRIPBOARD SCHEMATIC •

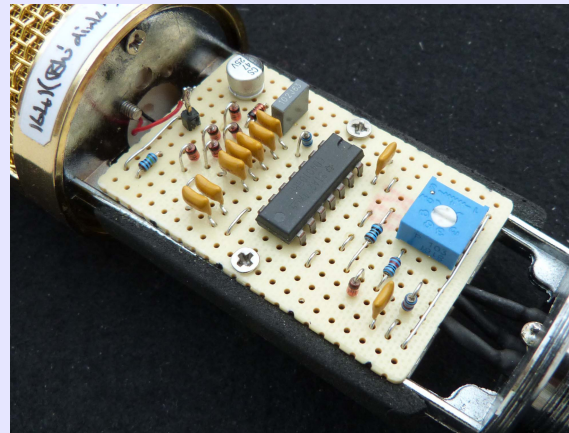
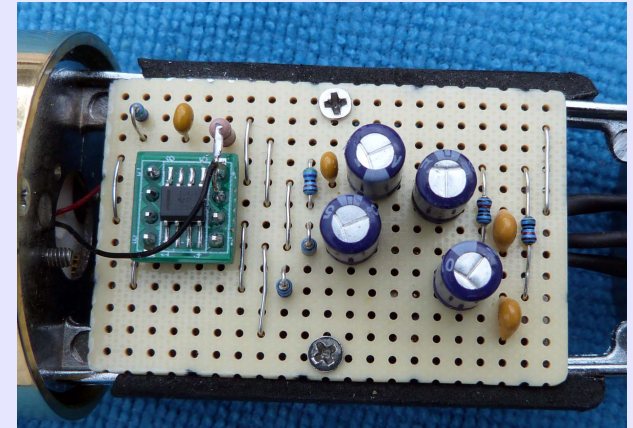
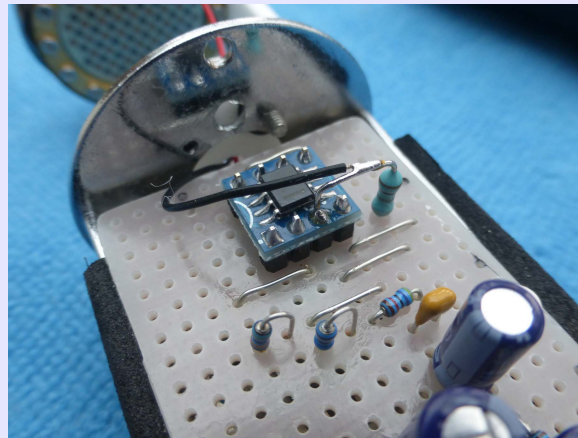
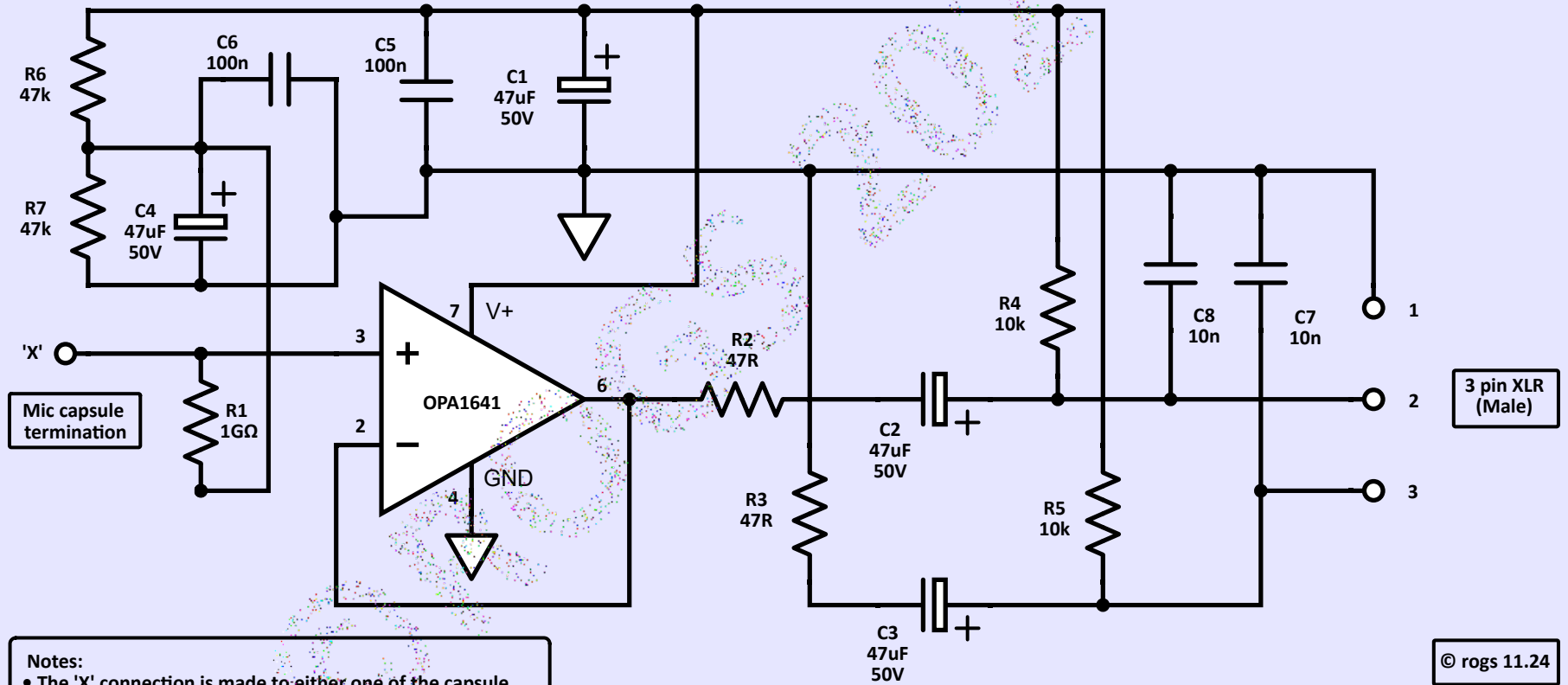

Notes:

- The 'X' connection is made to either one of the capsule terminations – normally the backplate.
- The second capsule connection is taken from the Voltage Multiplier output – normally the membrane terminal.
- Note that reversing these connections will invert the polarity of the microphone output.

## OPIC.43 Circuit description

### Overview:

The circuitry shown in the schematic uses a Texas Instruments OPA1641 JFET op-amp as an impedance converter for a condenser microphone capsule.

The circuit offers a simple alternative to the more conventional use of a discrete JFET device to perform this function..

The OPA164\* series of op-amps offer both low noise and low quiescent current, making them ideal for this task. There is also no need for any bias adjustments to be included, which further simplifies construction.

A single OPA1641 op amp is used here to provide a single sided audio output. The overall circuit does however provide a balanced output. The line is impedance balanced passively, to optimise the common mode rejection ratio (CMRR).

### Circuit description:

The OPA1641 is configured as a zero gain non-inverting buffer. The op-amp output is connected directly to the inverting input to achieve this.

The amplifier draws around 1.8mA of quiescent current, and this is provided by the 48v phantom power supply from the mic preamp. The resistor summing network R4 and R5 - together with the decoupling capacitors C1 and C5 – will allow a smoothed supply voltage of around 20v to be presented to pin 7 of the op-amp. The actual supply voltage is not critical, as the circuitry will automatically adjust the half rail reference to suit the supply voltage.

The op-amp requires a 'dual' voltage supply, and this is provided by the creation of a 'half rail' voltage of around 10v by the voltage divider R6 and R7, together with the decoupling capacitors C4 and C6.

This 'half rail' voltage is required to bias the op-amp, so that the output can swing symmetrically around this reference voltage. It is fed to the non-inverting input of the op-amp via R1, the high value 1GΩ resistor required to bias the purely capacitive capsule for effective function.

The LDC capsule used in this version requires an externally generated polarising DC voltage. (See the 'VM' schematic description for more details.)

The 'X' input connection on the schematic is connected to one capsule termination, the other being connected to the output of the VM voltage multiplier. The polarity of the microphone will depend on which capsule lead is connected to which termination.

The preferred option often seems to be to connect the backplate termination to the 'X' input, and the centre termination to the Voltage Multiplier output. The microphone polarity will be reversed if these connections are reversed.

*It is important to remember that the 'X' input is biased at positive 'half rail' (c.10v), and that DC value needs to be added to any selected voltage multiplier DC output, to determine the actual polarisation voltage applied to the capsule.*

The op amp output (pin 6) is connected via R2 and C2 to pin 2 (hot) of the XLR connector. C2 is required to isolate the DC 'half rail' voltage present on the output of the op-amp from the XLR output.

R3 and C3 provide an equivalent 'passively impedance balanced' output to pin 3 (cold) of the XLR connector.

There is no audio on this pin. R3 and C3 are fitted to improve the CMRR, which can be important when the mic is connected to a mic preamp via a long cable run.

C7 and C8 are included to decouple any stray RF interference which may be present.

Mic Capsule:  
Centre  
terminal  
connection  
to IC1 pin3  
and R1)

IC1 SOIC to  
DIP Adaptor :  
**DO NOT  
CONNECT  
PIN 3 TO  
STRIPBOARD**

**NOTE IC1  
Orientation:  
Pin 1 to F8**

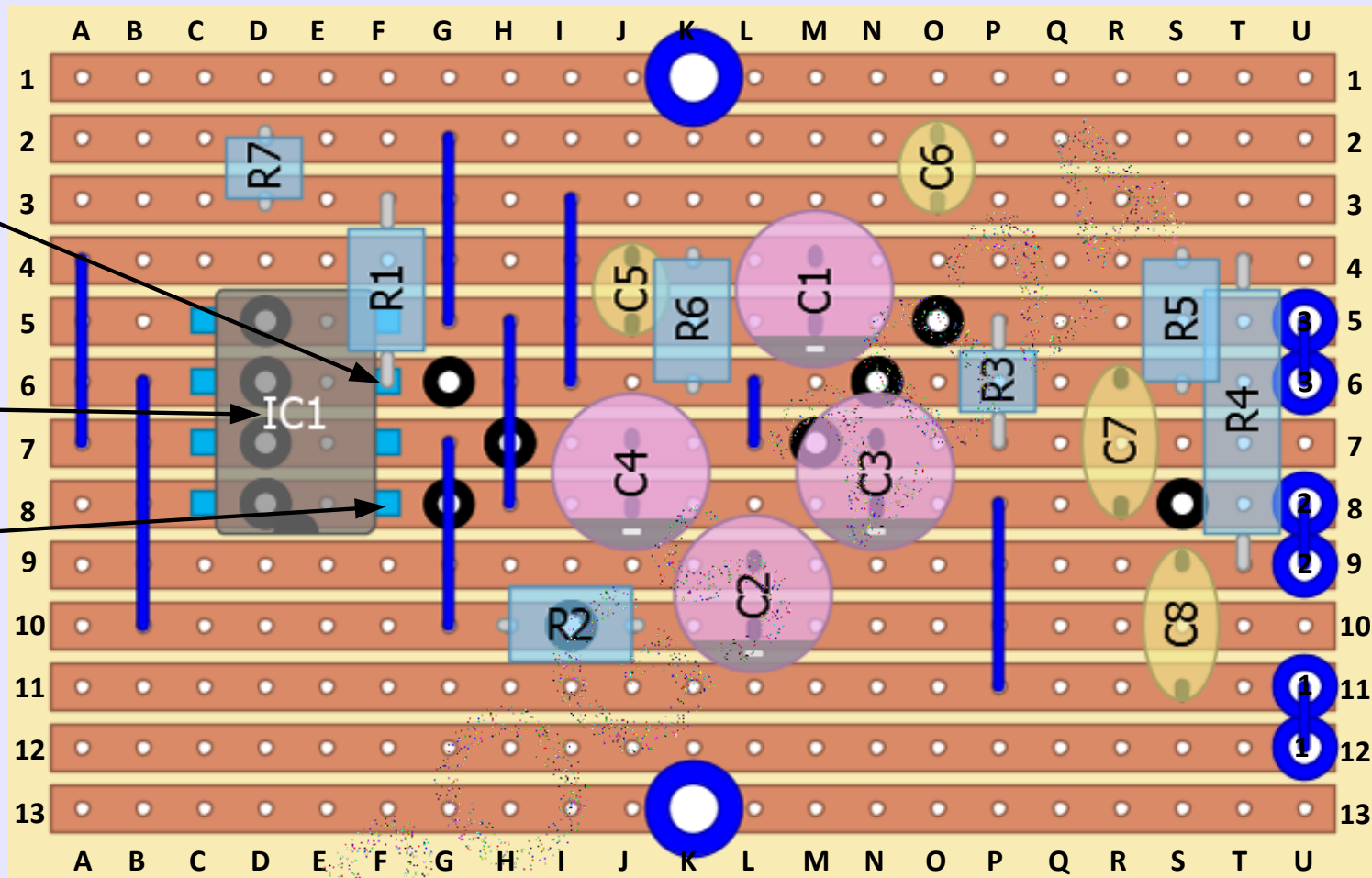

**OUT TO XLR**  
(Connections are  
double padded  
for simpler track  
side termination)

**OPIC.43 – stripboard**  
Complete stripboard component layout  
•• **VIEWED FROM COMPONENT SIDE** ••

- K1 and K13 are PCB mounting holes
- 10 x TCW links (marked as blue lines)
- 12 x 'spin off' track cuts (marked as black and white dots)

**Fit the components below:**

- C1 47uF 50V
- C2 47uF 50V
- C3 47uF 50V
- C4 47uF 50V
- C5 100n mlc (0.1")
- C6 100n mlc (0.1")
- C7 10n mlc (0.2")
- C8 10n mlc (0.2")
- C5-C8 are X7R 63V mlc

**All resistors (except R1) are MF12 1/8th watt MF**

- R1 1GΩ (10%)
- R2 47R
- R3 47R
- R4 10k
- R5 10k
- R6 47k
- R7 47k

- IC1 OPA1641 (via adaptor) (**Pin1 - F8**)

© rogs 11.24

**OPIC43 ADJUSTABLE DC VOLTAGE MULTIPLIER (45 TO 95V range)**  
Schematic Diagram

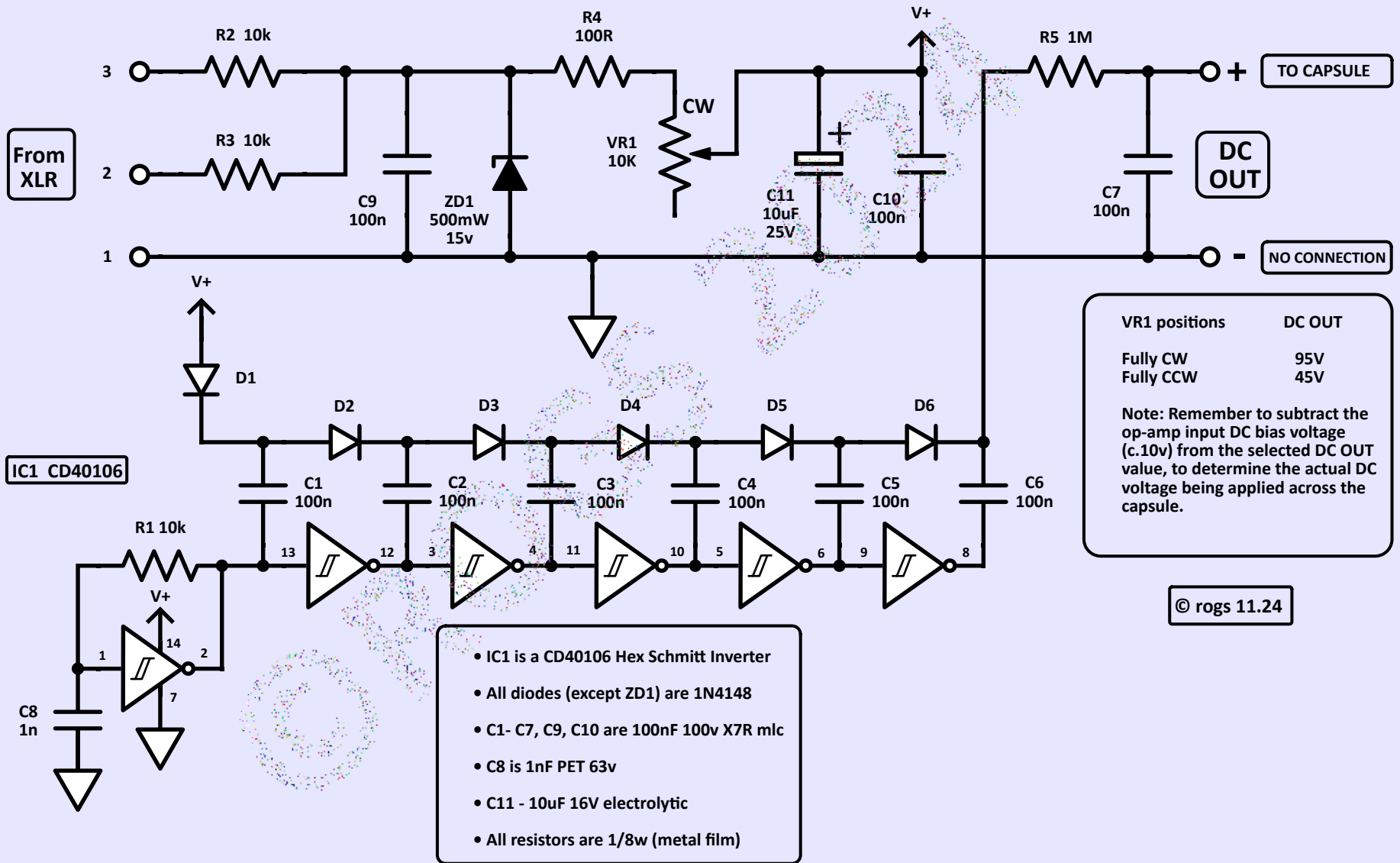

## OPIC43 Adjustable Voltage Multiplier Circuit Description

### Overview:

The circuitry shown in the schematic is designed to provide a high voltage DC output - adjustable between c.45v and c.95v - to be applied as the polarisation voltage required by a conventional condenser microphone capsule.

(Note that this facility is not required for electret capsules, which are pre-polarised as part of their manufacturing process)

This particular circuit uses a single CD40106 Schmitt Hex inverter IC - working as a Dickson Charge Pump - to generate a maximum 100v DC output from a 15 volt regulated DC supply input.

You can find more details of the Dickson Charge Pump concept here:

[https://en.wikipedia.org/wiki/Voltage\\_multiplier#Dickson\\_charge\\_pump](https://en.wikipedia.org/wiki/Voltage_multiplier#Dickson_charge_pump)

### Circuit description:

In this schematic, an oscillator running at c.125KHz is formed by R1, C8 and pins 1 and 2 of a CMOS CD40106 Hex inverter IC.

All 6 inverters - including the oscillator - are connected serially, with each output connected to the following input. The particular order of serial connection is not critical, and is selected here to simplify the stripboard layout.

Each sequential output will provide an opposite polarity output signal to the previous stage, thus providing the 2 alternate polarity clocks required to create a voltage multiplying charge pump.

Each in/out junction is further connected to one terminal of a 100nF capacitor, the second terminal of which is connected to a diode 'chain' formed by a series of 1N4148 diodes, D1 to D6.

This arrangement will permit the DC supply to the IC to be multiplied, with each diode stage adding c.15V to the output of the previous one, so that the voltage at the cathode of the final diode - D6 - is within the range 45v to 95v DC, depending on the position of VR1, the output calibration potentiometer.

The output DC from D6 cathode is fed to R5, which together with C7 form a low pass filter. The value selected for this filter will attenuate the ultrasonic clock pulses at c.125KHz by around 90dB, to provide a low ripple DC polarisation voltage for the capsule.

Note that the final DC output has a high impedance because of the value of R5, but as the load is only the mic capsule - which is essentially just a capacitor - there is very little drop in output voltage from the DC value measured at the cathode of D6, with respect to 'ground' (-V).

However, you will observe a drop in DC value of around 10% if you attempt to measure the value at the R5 - C7 junction with a conventional DMM, which is likely to have an impedance of around 10MΩ.

The circuit is powered by 48v phantom power. Feed resistors R2 and R3 take the phantom power voltage from both terminals of the balanced XLR plug. The Zener diode ZD1 will set the voltage at the junction of the 2 feed resistors to 15v. In total around 2.5mA is drawn from the phantom power supply - around 1.5mA for the CD40106 and around 1mA by the zener diode.

The exact value of the DC output at D6 cathode ( the best place to measure it accurately with a DMM) will depend on the setting of VR1. In a fully clockwise position (CW), the DC level measured will be c.95V. In the fully counterclockwise (CCW) position, the value will be around 45V.

The actual DC supply voltage at pin 14 of the CD40106 hex inverter IC will vary between c.9v and c.15v, depending on the position of VR1.

It should be noted that the latter few stages of the multiplier can develop up to 90v DC across the 100nF capacitors in the multiplier chain - and this is also true of C9 and C10. It is recommended that all the capacitors C1 - C7, plus C9 and C10 are all rated at 100v to simplify things.

***Remember to subtract the value of the OPA1641 op-amp 'half rail' input DC bias (c.10v) from the selected DC multiplier output voltage, when calculating the actual DC voltage being applied across the capsule.***

**OPIC43: 40106 Adjustable Voltage Multiplier - Complete stripboard component layout •• VIEWED FROM COMPONENT SIDE ••**

45 - 95V DC  
out to mic  
capsule

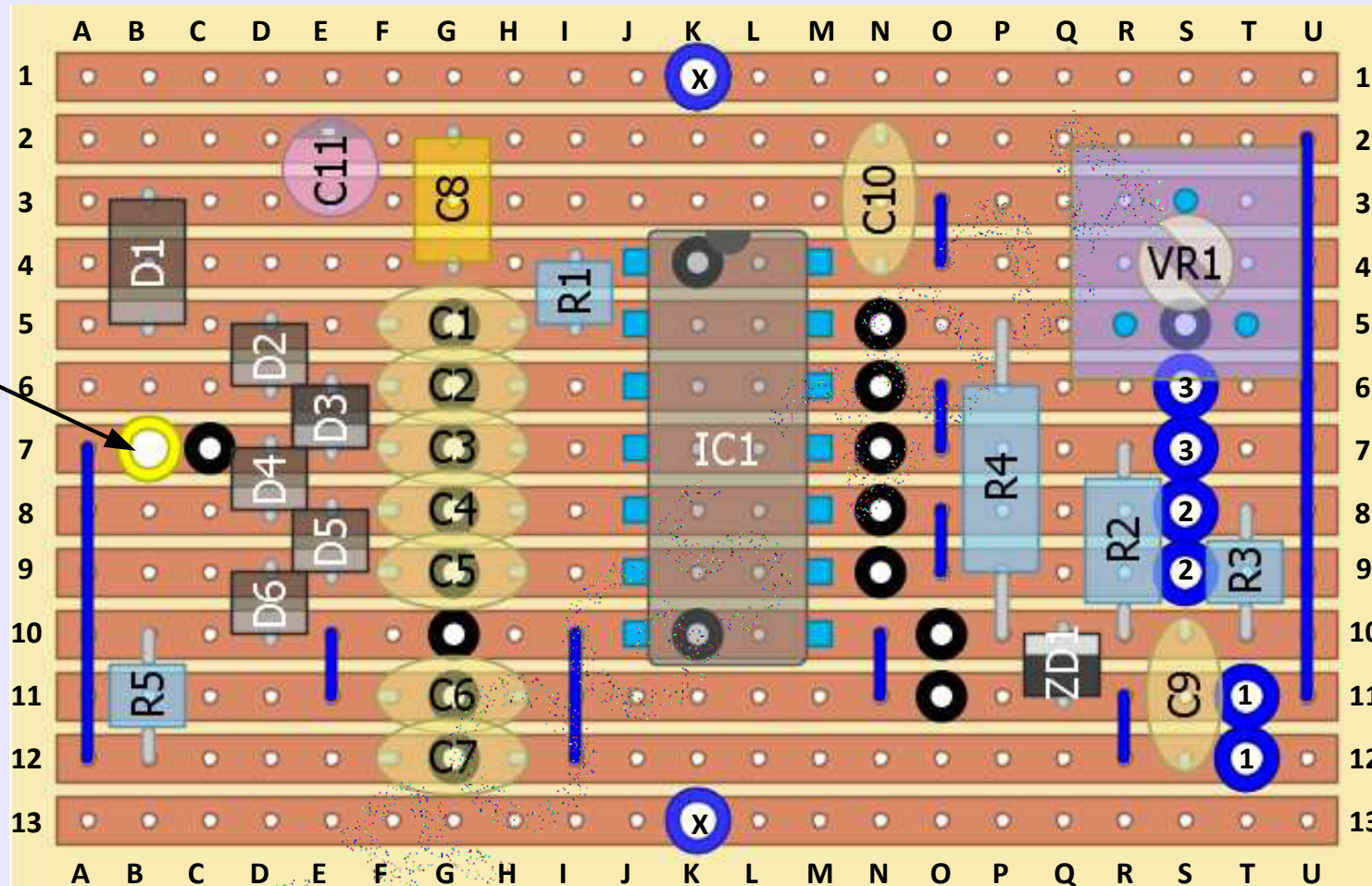

Terminals  
1, 2 & 3 to  
XLR  
(Double padded  
for simpler  
trackside  
connection)

- Adjust VR1 to obtain required DC output level
- Max. voltage in fully clockwise (CW) position

© rogs 11.24

- K1 and K13 ('X') are mounting holes
- 9 x TCW wire links - TCW25 or similar (marked as blue lines on schematic)
- 19 x track cuts - use track cutter or drill bit (marked as black & white dots on schematic)

**Fit the components to the locations listed below:**

- |                         |                                      |
|-------------------------|--------------------------------------|
| • C1 100nF mlc (F-H,5)  | • C9 100nF mlc (S10,S12)             |
| • C2 100nF mlc (F-H,6)  | • C10 100nF mlc (N2,N4)              |
| • C3 100nF mlc (F-H,7)  | • C11 10uF 16v elec (C3+,C2)         |
| • C4 100nF mlc (F-H,8)  | <b>Resistors are 1/8w metal film</b> |
| • C5 100nF mlc (F-H,9)  | • R1 10k (I4, I5)                    |
| • C6 100nF mlc (F-H,11) | • R2 10k (R7, R10)                   |
| • C7 100nF mlc (F-H,12) | • R3 10k (T9, T10)                   |
| • C8 1nF 63v PET(G2,H4) | • R4 100R (P5, P10)                  |
|                         | • R5 1M (B10, B12)                   |

• n.b. C1-C7,C9,C10 (mlc) capacitors are 100V X7R

- Diodes D1-D7 are 1N4148 (anode location 1st)
- D1 (E3,5) • D2(D5,6)
- D3 (E6,7) • D4 (D7,8)
- D5 (E8,9) • D6 (D9,10)
- ZD1 15v 500mW zener: (Q11(a),Q10(k))
- IC1 CD40106 ( Pin1 – J4)
- VR1 10K – R5,S3,T5