

- **OPIC.FS/2 - Op-amp Impedance Converter with Adjustable Dual Output Voltage Multiplier** •
- *Transformer coupled fully balanced output*
- *Selectable 2nd order high pass filter*
- *Iss.2: Pad depth accuracy improved*
- *Multi-pattern options for dual sided LDC capsules*
- *Lower polarisation voltage for adjustable pad output*
- *Designed to fit into a U87 style body*

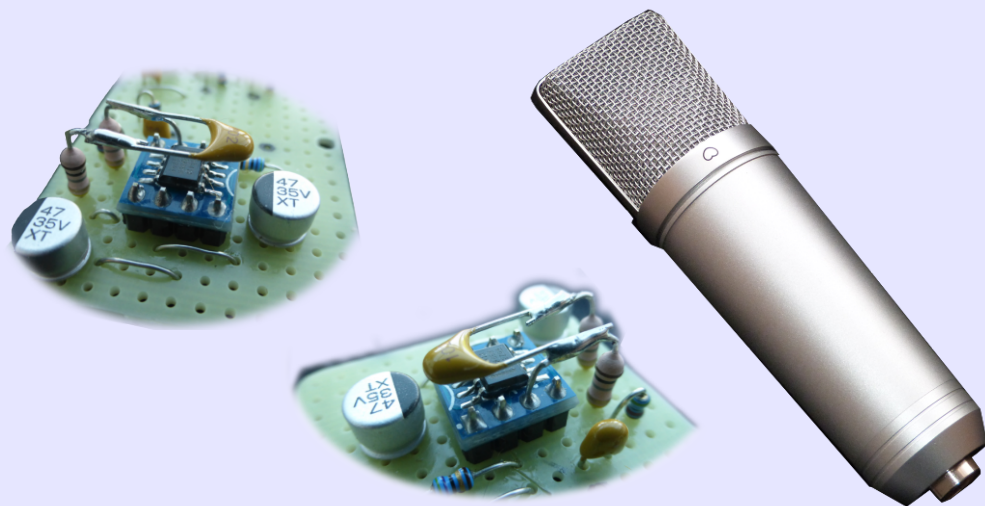

- Rev.1: • Original 10.25
- Rev.2: • Stripboards now 26 columns (originally 27)
- Rev.3 • Issue 2: Regulated op-amp DC supply added

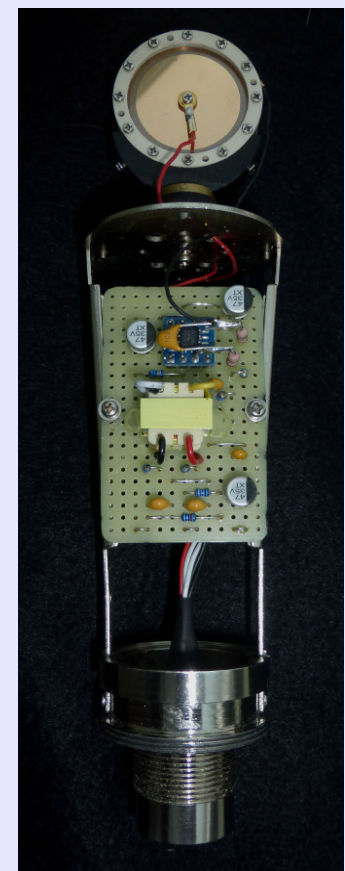
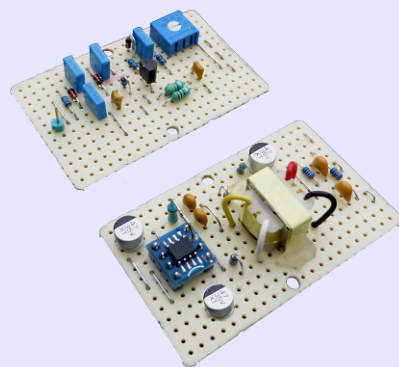
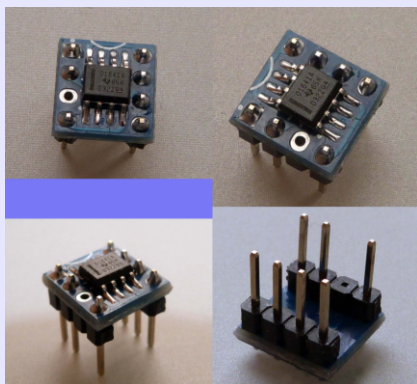

© rogs 02.26

OPIC.FS2 Op Amp Impedance Converter Schematic

- 2nd order Chebyshev High Pass Filter Option
- Transformer Coupled Balanced Output

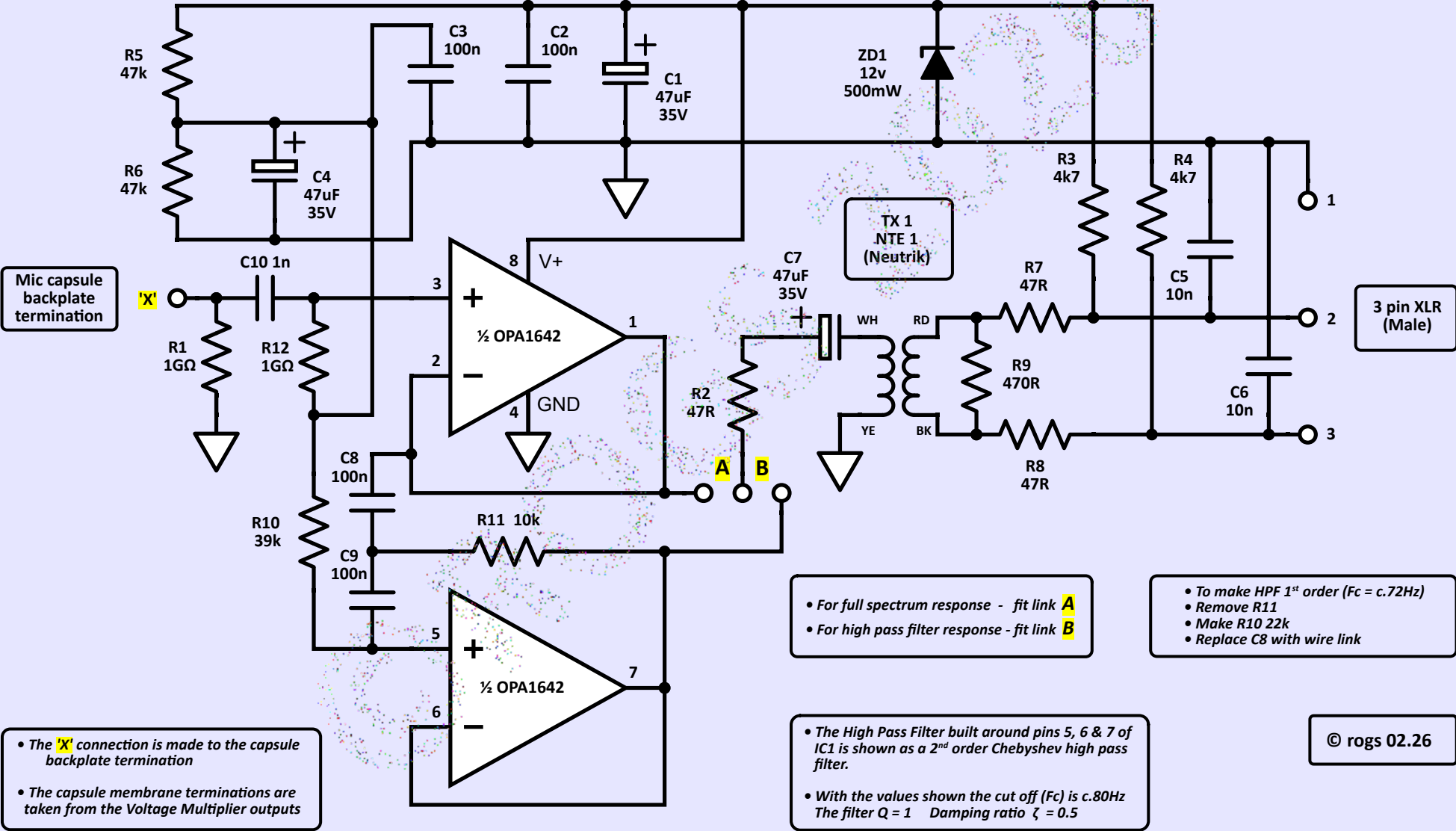

- The 'X' connection is made to the capsule backplate termination
- The capsule membrane terminations are taken from the Voltage Multiplier outputs

- For full spectrum response - fit link **A**
- For high pass filter response - fit link **B**

- To make HPF 1st order ($F_c = c.72\text{Hz}$)
- Remove R11
- Make R10 22k
- Replace C8 with wire link

- The High Pass Filter built around pins 5, 6 & 7 of IC1 is shown as a 2nd order Chebyshev high pass filter.
- With the values shown the cut off (F_c) is c.80Hz
The filter $Q = 1$ Damping ratio $\zeta = 0.5$

© rogs 02.26

OPIC.FS2 Circuit description

Overview:

The circuitry shown in the schematic uses a Texas Instruments OPA1642 dual JFET op-amp. One op-amp is configured as a unity gain buffer to act as an impedance converter for a condenser microphone capsule.

The second op-amp is configured as a 2nd order Chebyshev high pass filter, which has a cut off frequency set to c.80Hz, to provide an alternative signal path with low frequency attenuation, where this is required.

The OPA164* series of op-amps offer both low noise, very low distortion, and low quiescent current, making them ideal for this task. There is also no need for any special input bias adjustments to be included, which further simplifies construction.

The outputs from each op-amp are exclusively connected to a Neutrik transformer type NTE-1, to provide a balanced audio output - via pins 2 and 3 of the XLR connector - to the attached mic preamp.

Circuit description:

The OPA1642 amplifiers are both configured as unity gain non-inverting buffers. The op-amp output is connected directly to the inverting input to achieve this.

Each amplifier draws around 1.8mA of quiescent current, and this is provided by the 48v phantom power supply from the mic preamp.

The resistor summing network R3 and R4 - together with ZD1 and the decoupling capacitors C1 and C2 - will allow a smoothed supply voltage of 12v to be presented to pin 8 of the op-amp package.

The op-amp requires a 'dual' voltage supply, and this is provided by the creation of a 'half rail' voltage of 6v by the voltage divider R5 and R6, together with the decoupling capacitors C3 and C4.

This 'half rail' voltage is required to bias the op-amps, so that the output can swing symmetrically around this reference voltage, and is fed to the non-inverting inputs of each op-amp via R12 and R10.

R12 is a 1G Ω resistor. This high value is necessary to maintain the electrostatic charge on the capsule diaphragm, which acts as a low value 'variable' capacitor. A lower value resistor would result in a poor low frequency response.

To allow the capsule to be referenced to 0v (gnd), rather than the op-amp 'half rail' bias, a second 1G Ω resistor - R1 - is connected between the capsule input connection and 0v (gnd). This is AC coupled to the op-amp input via C10, which is 'air mounted' above the op-amp between R1 and R12, to help maintain the very high impedance input required by the capsule.

This configuration allows for the capsule backplate to be connected to 0v (gnd) via R1, and for a dual membrane capsule to have equal value DC polarisation voltages applied to the capsule membranes, with the polarity selected as required.

The dual membrane LDC capsule used in this version requires externally generated polarising DC voltages. (See the 'Adjustable Dual VM' schematic description for more details.)

The 'X' input connection on the schematic is connected to the capsule backplate, so that it becomes referenced to 0v (gnd) via R1.

The 'Adjustable Dual VM' outputs are applied to each capsule membrane to suit the required response pattern. Both capsule membranes to the positive voltage for an omni pattern, each membrane to opposite polarity voltages for figure of 8, and a single positive connection to the front membrane only, for cardioid pattern selection.

The first op-amp output (pin 1) is connected - via link 'A', R2 and C7 - to one end of the output transformer (TX1) primary winding. The other end of that winding is connected to 0v (gnd). The alternative high pass filter output (pin 7) is connected to the transformer via link 'B', R2 and C7.

The secondary winding is connected to pins 2 and 3 of the XLR connector, which provides a balanced output signal to the attached mic pre-amp.

R8 and R9 are included in series with the transformer secondary to allow for output impedance modifications. The nominal value is fitted as 47R, but this value can be changed to suit any specific requirements.

R10 is connected across the secondary winding of the transformer, to minimise any HF 'ringing' that may result from parasitic inductances.

C5 and C6 are included to help de-couple any stray RF interference which may be present to ground.

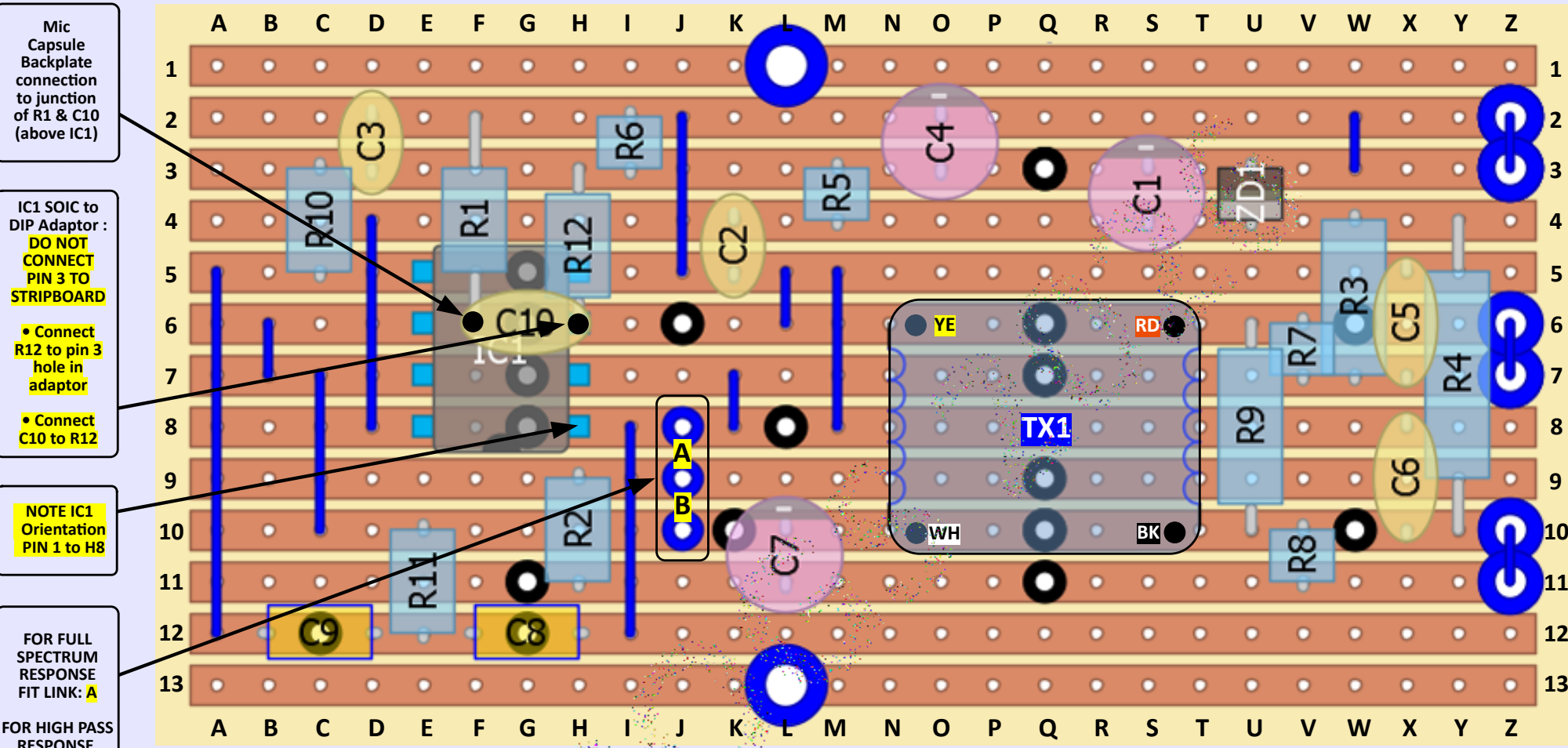

Mic Capsule Backplate connection to junction of R1 & C10 (above IC1)

IC1 SOIC to DIP Adaptor : **DO NOT CONNECT PIN 3 TO STRIPBOARD**

- Connect R12 to pin 3 hole in adaptor
- Connect C10 to R12

NOTE IC1 Orientation PIN 1 to H8

FOR FULL SPECTRUM RESPONSE FIT LINK: **A**

FOR HIGH PASS RESPONSE FIT LINK: **B**

High Pass Filter is 2nd order Chebyshev with an Fc of c.80Hz

- Rev.1: Original 10.25
- Rev.2: 11.25 Stripboard now 26 columns

OPIC. FS2 – STRIPBOARD

- FC2 or FC4 (KEMO E005)
- 13 (copper tracked) rows
- 26 columns
- **VIEWED FROM COMPONENT SIDE**

- L1 and L13 are mounting holes
- 13 x TCW links (marked as blue lines)
- 18 x 'spin off' track cuts (marked as black and white dots)

Fit the components listed below:

- C1 47uF 35V
- C2 100n 63V mlc
- C3 100n 63V mlc
- C4 47uF 35V
- C5 10n 63V mlc
- C6 10n 63V mlc
- C7 47uF 35V
- C8 100n 63v PET
- C9 100n 63v PET
- C10 10n 63v mlc

All resistors (except R1 & R12) are MF12 1/8th watt

- R1 & R12 1GΩ (10%) (RGP0207CHK1G0 or similar)
- R2 47R • R3 4k7
- R4 4k7 • R5 47k
- R6 47k • R7 47R
- R8 47R • R9 470R
- R10 39k • R11 10k

- IC1 OPA1642 (via adaptor) (**Pin1 - F8**)
- ZD1 12vZener (500mW)
- TX1 NTE-1 (Neutrik)

Connections 1,2 & 3 out to XLR

(Double padded for simpler track side termination)



OPIC.FS2.VM - DUAL OUTPUT VOLTAGE MULTIPLIER

- ADJUSTABLE PRIMARY OUTPUT VOLTAGE
- ADJUSTABLE PAD OUTPUT VOLTAGE

© rogs 02.26

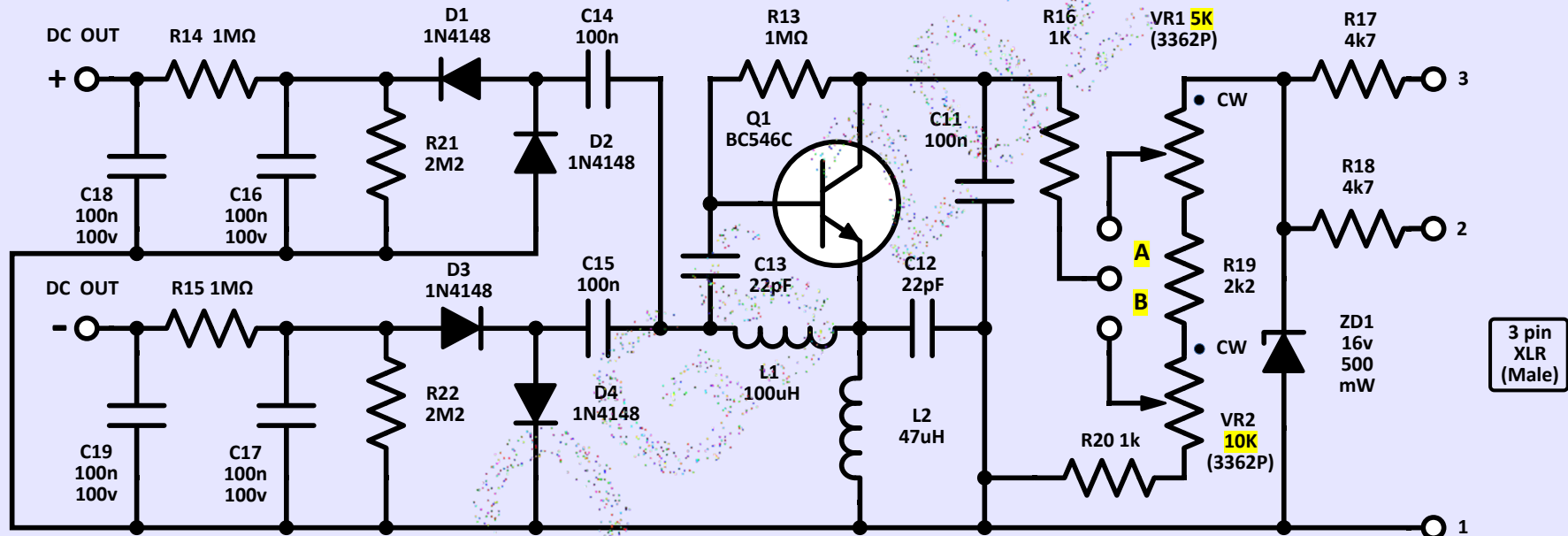

To calibrate primary output voltage:

- Fit link **A**
- Connect DMM between D1 cathode and 0v (ground)
- Adjust VR1 until required DC is measured on DMM
- Range is c.+40v to c.+95v (-ve voltage will calibrate automatically)

To calibrate pad output voltage:

- Fit link **B**
- Connect DMM between D1 cathode and 0v (ground)
- Adjust VR2 until required DC is measured on DMM

- For -10dB pad set VR2 for 31.6% of primary voltage
- For -20dB pad set VR2 for 10% of primary voltage

- Leave either link **A** or link **B** in place to enable the appropriate output voltage to be applied to the capsule.
- Links can be replaced with an SPDT switch, if required.

Typical results with component values shown:

- Primary output voltage: c. $\pm 40\text{v}$ to $\pm 95\text{v}$ (Adjust using VR1)
- Pad output voltage: c. $\pm 3\text{v}$ to $\pm 30\text{v}$ (Adjust using VR2)
- Max volts: With VR1 and VR2 fitted as 3362P: CW (CW= clockwise)
- Oscillator frequency: c. 2MHz
- Current: c. 3.0mA

OPIC.FS2 - Dual Adjustable Voltage Multiplier

Overview:

The circuitry shown in this schematic is designed to provide dual polarity high voltage DC outputs - adjustable between c. $\pm 40\text{v}$ and $\pm 95\text{v}$ - to be applied as the opposite polarisation voltages required by each membrane of a dual sided conventional large diameter condenser microphone capsule.

This will enable 3 alternative response patterns - Omni, Figure of 8 or Cardioid - to be selected for the microphone.

In addition, the option to output an adjustable lower voltage output within the range c. $\pm 3\text{v}$ and c. $\pm 30\text{v}$ will allow for a preset attenuation 'pad' to be applied to both outputs

DC power to the circuitry is supplied from the 48v phantom power of the connected mic pre-amp. About 3mA will be drawn by this circuit.

Circuit description:

This particular circuit is based on a Hartley oscillator, the output of which is coupled to 2 x voltage doubling circuits, one of which provides a positive output voltage, the second a negative one.

There are a number of alternative possible configurations for a Hartley oscillator. The one chosen for this project follows the format used by Schoeps, in their famous 'CMC5' microphone schematic.

There are many online technical items on Hartley oscillators. The notes here:

<https://learnabout-electronics.org/Oscillators/osc21.php>

provide some interesting insights, particularly regarding mutual coupling of the inductors, which can play an important role in the layout of the oscillator components.

In this schematic, a Hartley oscillator running at c.2MHz is formed by the components connected to Q1. The amplitude of the oscillator output, which is taken from the junction of L1 and C13, will be a sine wave that will vary in amplitude between c.0v and 95v (p-p), depending on the positions of VR1 and VR2.

Notice the positions of the 2 inductors L1 and L2 on the stripboard. Although not critical, it is recommended that the inductors are laid with the same orientation, in adjacent 0.1" stripboard rows.

That should provide for an appropriate level of mutual inductive coupling between the inductors, for reliable oscillator operation.

(N.B. - The resistor and capacitor idents on this stripboard start as C11 and R13, to avoid confusion with component idents on the project preamp stripboard).

The oscillator output is fed - via C14 - to the junction of D1 anode and D2 cathode. D1 and D2 - in conjunction with C14 and C16 - form a voltage doubling circuit, which will produce a rectified DC output of between c.+40v and c.+95v at D1 cathode. R 21 is fitted to provide a small DC load to the doubler, to allow for a reliable transfer to the lower pad voltage output. R14 and C18 act as a low pass filter, to allow a smoothed DC voltage to be present at the junction of those two components. This DC output is connected to one membrane of the capsule.

The oscillator output is also fed - via C15 - to the junction of D3 cathode and D4 anode. The same voltage doubling process takes place, using C15 and C17, but this time creating a negative DC output, because of the reverse orientations of D3 and D4. R22 provides the DC load to the negative doubler. In this case R15 and C19 act as the low pass filter. The negative DC output is connected to the other membrane of the capsule.

The selection of either link A or link B will allow either VR1 or VR2 to adjust the output voltage. VR1 adjusts the primary output voltage, whilst VR2 allows for a lower voltage in the range c. $\pm 3\text{v}$ to c. $\pm 30\text{v}$ to be generated. This will permit lower polarisation voltages to reduce the sensitivity of the capsule, and apply an attenuation 'pad' where required. Either link A or B should be left inserted to select the appropriate output voltages to the capsules.

Note that capacitors C16,17,18 & 19 need to be rated at 100v rather than the more common 63v type that can apply to other capacitors in this circuit.

R17 and R18 will feed both legs of the 48 v phantom power from the mic pre-amp to the cathode of ZD1. The regulated 16v DC supply from this point is fed - via the adjustable resistor VR1 or VR2 - to the collector of Q1. C11 serves to decouple this supply.

The adjustable DC voltage available at this point will determine the amplitude of the oscillator output, and thus the value of the final DC outputs as a result.

To determine the actual value of DC being supplied to the outputs, it is recommended that DMM measurements are taken from D1 cathode, and not from the actual output terminations themselves. This will minimise the effect the impedance of the DMM has on the observed voltage readings.

Note that the negative voltage at D3 anode will automatically mirror the positive voltage measured at D1 cathode

Rev.1: • Original layout 10.25
 Rev.2: • Now 26 columns (was 27)
 Iss2: • ZD1 now 16v

OPIC.FS2: Dual Output Voltage Multiplier
 • Adjustable primary voltage • Adjustable secondary (pad) voltage

© rogs 02.26

Connections 1, 2 and 3 are out to 3 pin XLR
 (Connections are 'double padded' for easier termination)

3

2

1

Output Links
 • Link A : Primary voltage
 • Link B : Pad voltage

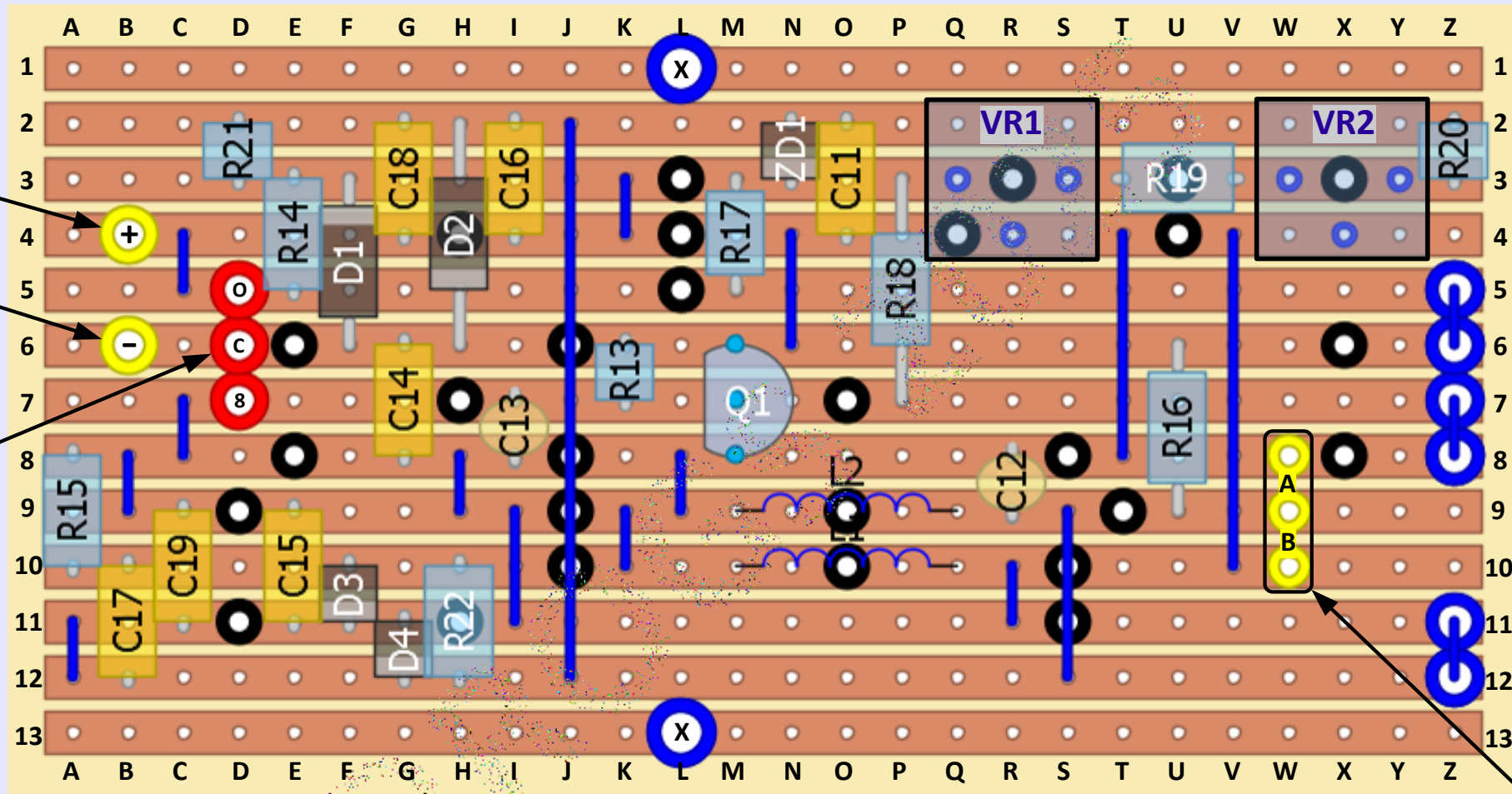

DC to capsule (front side)

DC to capsule (rear side)

Pattern Links
 • Omni: O-C
 • Fig of 8: C-8
 • Cardioid: No link

- Stripboard: FC4 or FC2 (Kemo E005)
- 13 x rows (continuous copper tracks)
- 26 x columns
- 18 x TCW wire links - TCW25 or similar (marked as blue lines on schematic)
- 28 x track cuts – 'spin off' with track cutter or drill bit (marked as black & white dots on schematic)
- L1 and L13 ('X') are mounting holes

• Do not forget track cuts under D2 (H4) , R19 (U3) & R22 (H11)

Components:

Semiconductors:

- Q1: BC546c
- D1,2,3 & 4: 1N4148
- ZD1: 16v 500mW Zener Diode

Capacitors:

- C11,14,15,16,17,18 & 19: 100nF **100v** (PET box cap - 0.2")
- C12,C13: 22pF ceramic (0.1")

Resistors:

- R13,14 & 15: 1M
- R17 & 18: 4k7
- R21 & 22: 2M2
- VR1: 5K -- VR2: 10K (Bourns type 3362P)
- R16 & 20: 1k
- R19: 2k2
- (All MF12 1/8w metal film)
- (Both MF25 1/4w metal film)

Inductors (Bourns 78F or similar):

- L1: 100uH
- L2: 47uH